

VESTNES WORKSHOP CABINETS

– designed for tough environments



by
 VESTNES
PRODUKT AS

LONG LIFE SPAN

Vestnes Produkt AS's workshop cabinets are specially adapted to be used on-board ships and offshore. We have developed the cabinets in cooperation with users from ships and offshore installations. This has resulted in a high-quality product with exceptionally good utility value. The use of thick electrolytically galvanized panels means the cabinets have a very long life span. The cabinets can also be produced in acid-proof stainless steel.

PRACTICAL SOLUTIONS

Our cabinets are made from 1.25 mm thick panels, giving a high-quality finish. The sides, back, shelves and door frames are screwed together to ensure good stability and prevent rattling. The doors on our biggest cabinets have three-point fastenings. The doors are assembled in an all-welded

frame to prevent dust from getting in.

The cabinets can be delivered without doors and with open shelves, which have a front lip to prevent objects falling out. The drawer shelves have a spot-welded lining and come with drawer stops. All our models are made of electrolytically galvanized panels, have strengthened bases and are powder coated in colour RAL 9002 (light grey).

FITTING

The cabinets can be delivered pre-assembled by the manufacturer or in kit-form for the customer to assemble on board. A fitter from Vestnes is also available if required. All our cabinets come with assembly instructions. There are 12 standard layouts, but the cabinets can be installed as you wish. If you require internal fittings made to measure, we are happy to help.



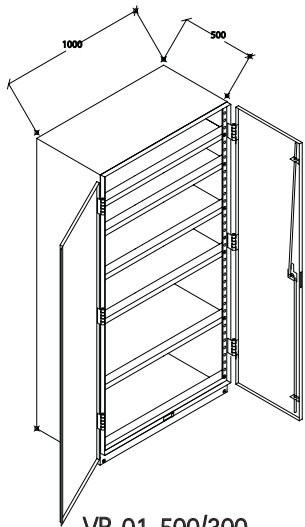

VP-01-500/300

Height: 2020 mm – Width: 1000 mm
Depth: 500 eller 300 mm
Weight: 94 kg excl. doors (32 kg)
Colour: RAL 9002

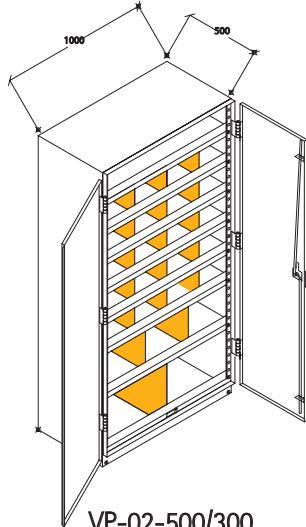

VP-02-500/300

Height: 2020 mm – Width: 1000 mm
Depth: 500 eller 300 mm
Weight: 124 kg excl. doors (32 kg)
Colour: RAL 9002

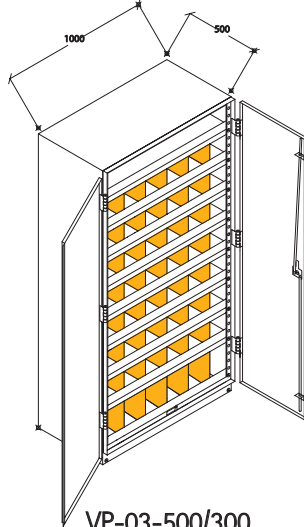

VP-03-500/300

Height: 2020 mm – Width: 1000 mm
Depth: 500 eller 300 mm
Weight: 149 kg excl. doors (32 kg)
Colour: RAL 9002

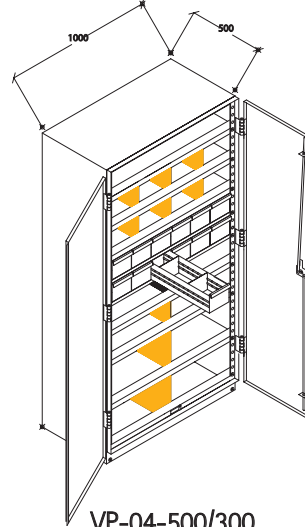

VP-04-500/300

Height: 2020 mm – Width: 1000 mm
Depth: 500 eller 300 mm
Weight: 142 kg excl. doors (32 kg)
Colour: RAL 9002

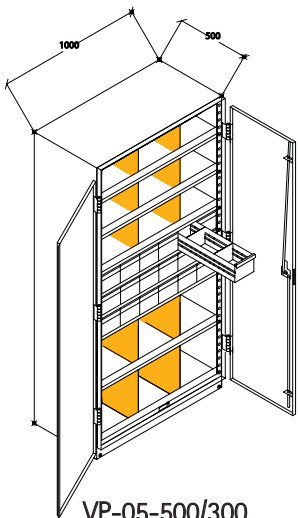

VP-05-500/300

Height: 2020 mm – Width: 1000 mm
Depth: 500 eller 300 mm
Weight: 146 kg excl. doors (32 kg)
Colour: RAL 9002

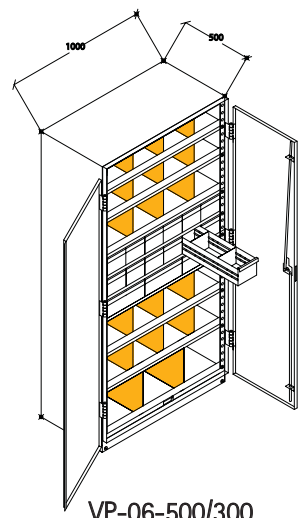

VP-06-500/300

Height: 2020 mm – Width: 1000 mm
Depth: 500 eller 300 mm
Weight: 157 kg excl. doors (32 kg)
Colour: RAL 9002

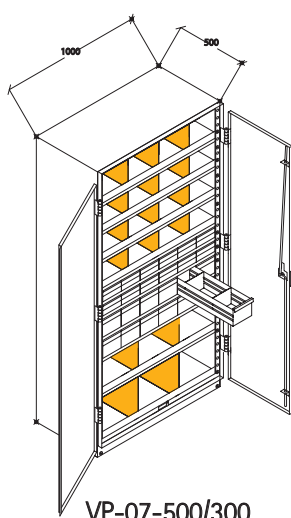

VP-07-500/300

Height: 2020 mm – Width: 1000 mm
Depth: 500 eller 300 mm
Weight: 169 kg excl. doors (32 kg)
Colour: RAL 9002

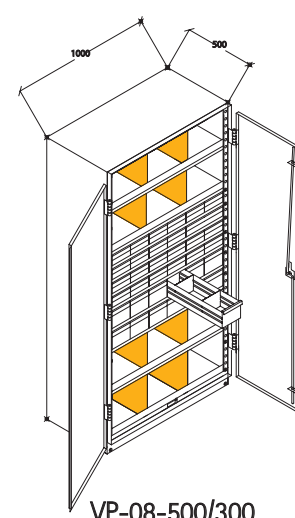

VP-08-500/300

Height: 2020 mm – Width: 1000 mm
Depth: 500 eller 300 mm
Weight: 180 kg excl. doors (32 kg)
Colour: RAL 9002

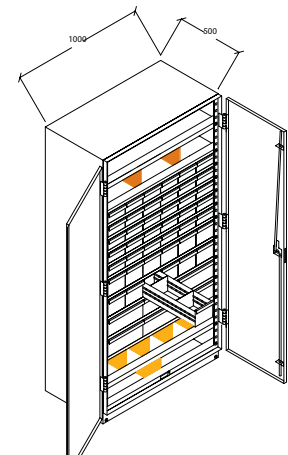

VP-09-500/300

Height: 2020 mm – Width: 1000 mm
Depth: 500 eller 300 mm
Weight: 217 kg excl. doors (32 kg)
Colour: RAL 9002

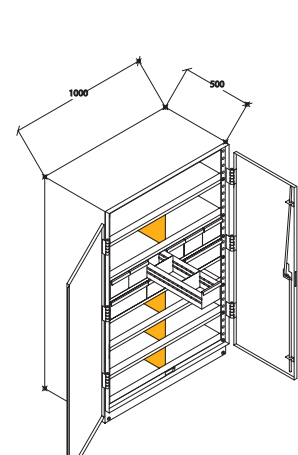

VP-10-500/300

Height: 1520 mm – Width: 1000 mm
Depth: 500 eller 300 mm
Weight: 104 kg excl. doors (25 kg)
Colour: RAL 9002

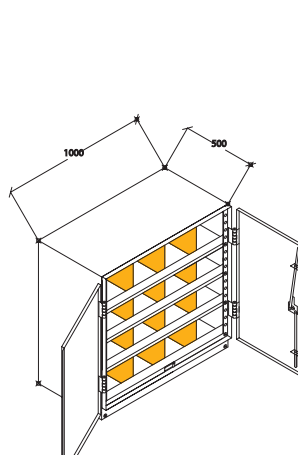

VP-11-500/300

Height: 920 mm – Width: 1000 mm
Depth: 500 eller 300 mm
Weight: 67 kg excl. doors (16 kg)
Colour: RAL 9002

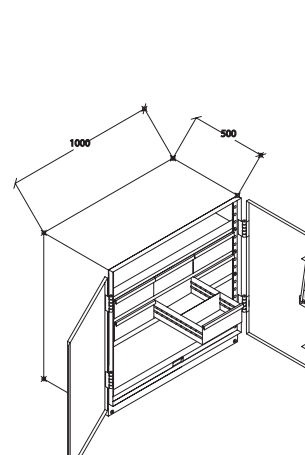

VP-12-500/300

Height: 920 mm – Width: 1000 mm
Depth: 500 eller 300 mm
Weight: 72 kg excl. doors (16 kg)
Colour: RAL 9002

OTHER PRODUCTS

In cooperation with Vestnes Innredning AS, Vestnes Produkt has developed a stainless steel shelf system for fridge/freezer and provision/storage rooms. The shelves are made to measure for optimal utilisation of each room. These shelves are also quick and easy to install. Our associated company specialises in the furnishing of ships of all sizes. By combining Vestnes Produkt's knowledge of steel and Vestnes Innredning's expertise in internal furnishing, we are able to solve most problems.

VESTNES PRODUKT AS

P.O.Box 409
N-6901 Florø, Norway
Phone: +47 57 75 20 60
Telefax: +47 57 75 20 61
e-mail: post@vestnes-produkt.no
www.vestnes-produkt.no

www.vestnesocean.com – e-mail: post@vestnesocean.com

Please feel free to contact us for more information or a no-obligation offer.

VESTNES PRODUKT AS

is located in the town of Florø, which lies in the county of Sogn og Fjordane. We manufacture heaters for both the Norwegian and the European markets. We also make interior furnishings and manufacture a considerable number of parts for other suppliers. When using our product, you will benefit from our experience, constant development and innovation.

